

LOCK INTO THE ACSI ADVANTAGE



S E R I E S 5 6 5 0 C O N T R O L C O N S O L E S



SERIES 5650 CONTROL CONSOLES

ACSI Series 5600 Control Consoles provide centralized control and monitoring of openings equipped with electric locking devices and/or door position switches.

Features

- Desk top mount with sloped front
- Individual channel lock/unlock and monitoring
- Built-in 2 amp power supply
- Green and red status LED's
- Internal audible alarm
- Two through six channel control
- Alarm acknowledge reset switch
- Choice of fail safe or fail secure control per channel

Size Requirements

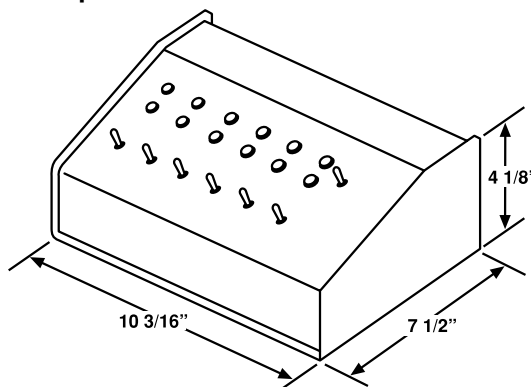

TYPICAL INSTALLATION

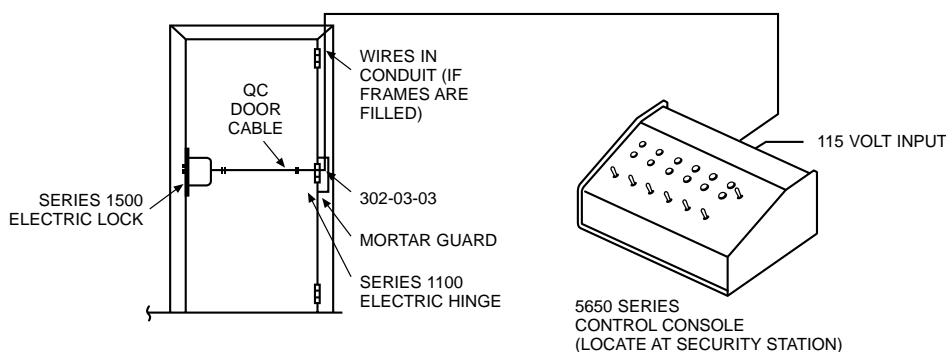

OPERATING VOLTAGE

Part Number	Total Current	Current Per Channel	Standard Voltage
5650-02	2 amps	1 amp	24VDC
5650-03	2 amps	.67 amp	24VDC
5650-04	2 amps	.5 amp	24VDC
5650-05	2 amps	.4 amp	24VDC
5650-06	2 amps	.33 amp	24VDC

HOW TO ORDER

